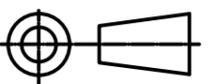

4	1	lamp.ipt			Kopen	
3	2	spak.ipt	S455		kopen	
2	1	lamp beugel.ipt	S235			
1	10	STRIP	S235			
STU	AAN	BENAMING	MATERIAAL	NORMAANDUIDIN	OPMERKINGEN	
RUWHEID VOLGENS NEN 3634		ISO-PASSINGEN NEN-ISO 286-1 EN-2		● PLAATS LEERLINGNUMMER		
AMERIKAANSE PROJECTIE		SCHAAL 1:2	GETEKEND ROSEBOOM		VORM- EN PLAATSTOLERANTIES VOLGENS NEN-ISO 1101	
		MAATEENHEID MM	KLAS 1			
		DATUM OKT 2011	GEZIEN ROSEBOOM			
		Benaming LAMPEKAP SAMENSTELLING			Tekening Nr. 1 van 3	Formaat A3

6

5

4

3

2

1

D

D

C

C

B

B

A

A

6

5

4

3

2

1

v2010

A (1:1)

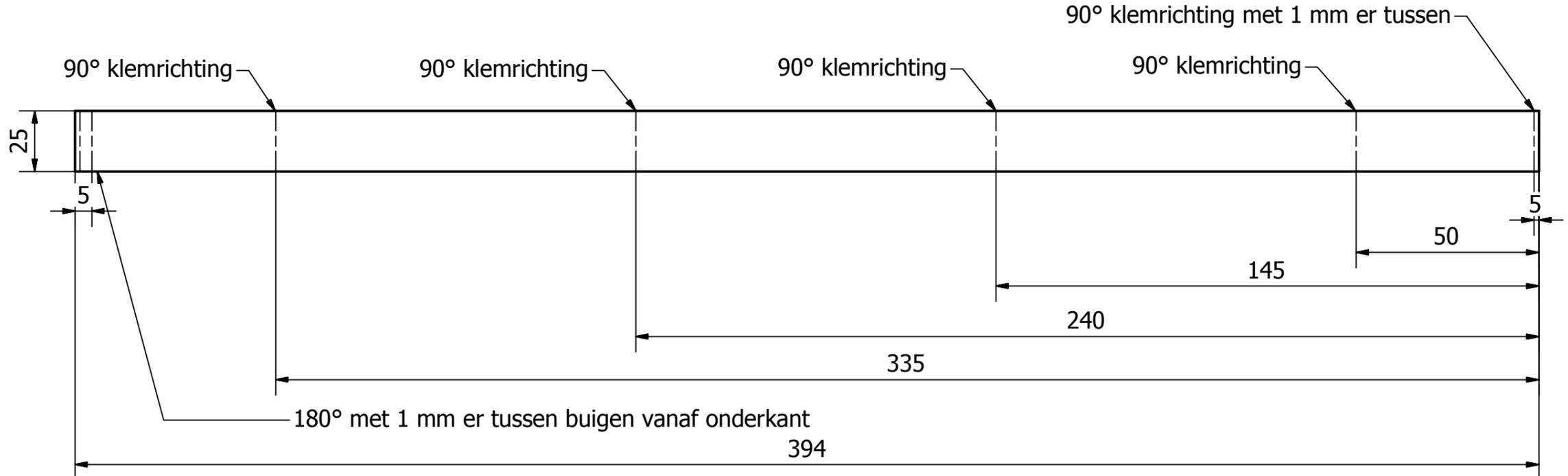
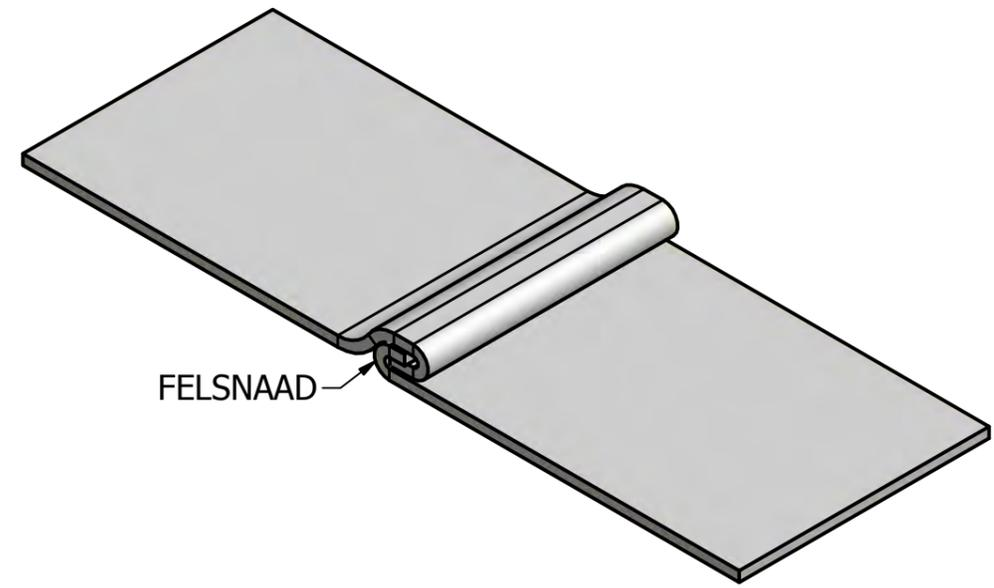
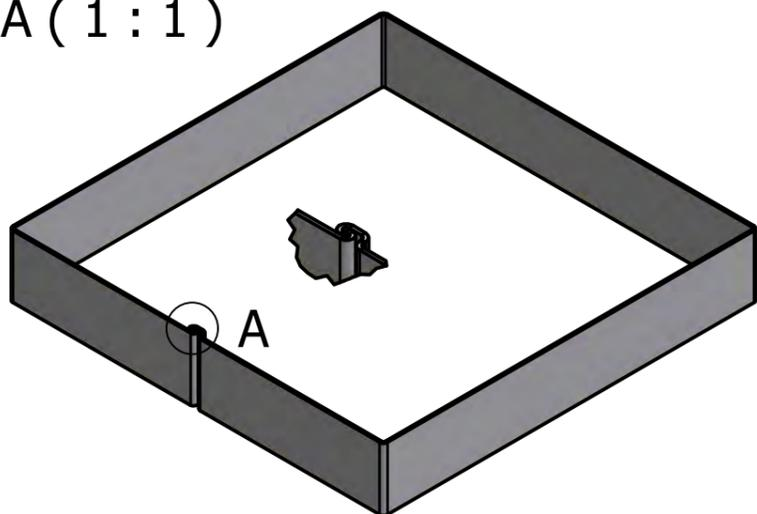

PASMAKEN BINNEKANT

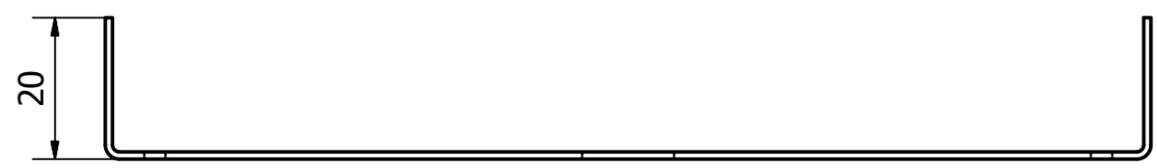
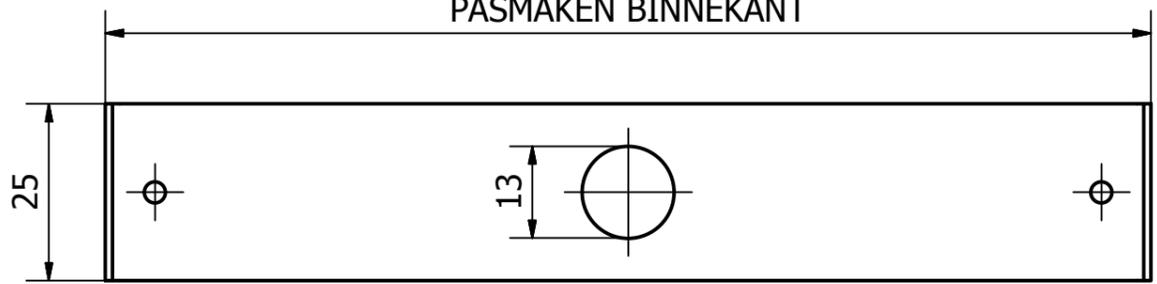

1	11	plaatdeel omtrek.ipt	S235		394 mm
STU	AAN	BENAMING	MATERIAAL	NORMAANDUIDIN	OPMERKINGEN
RUWHEID VOLGENS NEN 3634		ISO-PASSINGEN NEN-ISO 286-1 EN-2			● PLAATS LEERLINGNUMMER
AMERIKAANSE PROJECTIE		SCHAAL 1:1	GETEKEND ROSEBOOM		VORM- EN PLAATSTOLERANTIES VOLGENS NEN-ISO 1101
		MAATEENHEID MM	KLAS 1		
		DATUM 17-10-2012	GEZIEN ROSEBOOM		
		Benaming LAMPEKAP KLEIN			Tekening Nr. 3 van 3
		MODEL₂			Formaat A3

PRODUCED BY AN AUTODESK EDUCATIONAL PRODUCT

PRODUCED BY AN AUTODESK EDUCATIONAL PRODUCT